

• 120 & 240 Vac Models

Models SST120 and SST240 auxiliary function modules gradually apply power to the load when energized by the control voltage. They must be used with Crydom Series 1 (-10) random turn-on solid state relays. Consult fac-

tory about use with 480 Vac loads. For a complete set (control module and solid state relay) order 10SST120, 25SST120, etc.

Manufactured in Crydom's ISO 9002 Certified facility for optimum product performance and reliability.

| MODEL NUMBERS | 120 Vac | 10SST120 | 25SST120 | 40SST120 | | |
|-----------------------------------------------------------------------|-----------------------------------------------------|-----------|-----------|-----------|-----------|----------|
| | 240 Vac | 10SST240 | 25SST240 | 50SST240 | 75SST240 | 90SST240 |
| RELAY OUTPUT SPECIFICATIONS ① | | | | | | |
| Operating Voltage Range (47-63 Hz) [Vrms] | 90-140 (120 Vac Models) 180-280 (240 Vac Models) | | | | | |
| Load Current Range ③ [Arms] | .04-10 | .04-25 | .04-50 | .04-75 | .04-90 | |
| Transient Overvoltage [Vpk] | 400 (120 Vac models) 600 (240 Vac models) | | | | | |
| Max. Surge Current, (16.6ms) [Apk] | 120 | 250 | 625 | 1000 | 1200 | |
| Max. On-State Voltage Drop @ Rated Current [Vpk] | 1.6 | 1.6 | 1.6 | 1.6 | 1.6 | |
| Thermal Resistance Junction to Case (R _{θJC}) [°C/W] | 1.48 | 1.02 | .63 | .31 | .28 | |
| Maximum I ² t for Fusing, (8.3 msec.) [A ² sec] | 60 | 260 | 1620 | 4150 | 6000 | |
| Max. Off-State Leakage Current @ Rated Voltage [mArms] | 10.0 | 10.0 | 10.0 | 10.0 | 10.0 | |
| Min. Off-State dv/dt @ Max. Rated Voltage [V/μsec] ② | 500 | 500 | 500 | 500 | 500 | |
| Max. Turn-Off Time | 1/2 cycle | 1/2 cycle | 1/2 cycle | 1/2 cycle | 1/2 cycle | |
| Power Factor (Min.) with Max. Load | 0.5 | 0.5 | 0.5 | 0.5 | 0.5 | |

CONTROL MODULE INPUT SPECIFICATIONS (Terminal 3B) ①

| | DC CONTROL |
|-----------------------------------|--------------|
| Control Voltage Range | 3.5-10Vdc |
| Max. Turn-On Voltage | 3.5 Vdc |
| Min. Turn-Off Voltage | 1.0 Vdc |
| Typical Input Current | 1.6mA @ 5Vdc |
| Nominal Turn-On Delay Time @ 60Hz | 150 msec |
| Nominal Swell (Ramp) Time @ 60Hz | 180 msec |
| Max. Reset Time | 100 msec |

CONTROL MODULE OUTPUT SPECIFICATIONS (Terminal 4B-Input to relay) ①

| | DC CONTROL |
|----------------------------------|------------|
| Max. Off-State Operating Voltage | 36 Vdc |
| Max. Load Current (Sink) | 3.0 mAdc |
| Max. On-State Voltage @ 3mA | 0.5 Vdc |
| Max. Off-State Leakage @ 10Vdc | 1.0 mAdc |

GENERAL NOTES

- ① All parameters at 25°C unless otherwise specified.
- ② Off-State dv/dt test method per EIA/NARM standard RS-443, paragraph 13.11.1
- ③ Heat sinking required (Relay Only), see Series 1 data sheet.

© 2007 CRYDOM Inc., Specifications subject to change without notice.

GENERAL SPECIFICATIONS

| | |
|-------------------------------------|--------------|
| Dielectric Strength, Signal to Load | 4000 Vrms |
| Dielectric Strength, Signal to Base | 4000 Vrms |
| Ambient Operating Temperature Range | -30 to 80°C |
| Ambient Storage Temperature Range | -40 to 125°C |

MECHANICAL SPECIFICATIONS

| | |
|-------------------|----------------------------|
| Weight: (typical) | 3.0 oz. (43g) |
| Encapsulation: | Thermally Conductive Epoxy |

AVAILABLE OPTIONS

- SST120** Control Module Only (120 Vac line)
- SST240** Control Module Only (240 Vac line)

DERATING CURVES - See Series 1

WIRING DIAGRAM

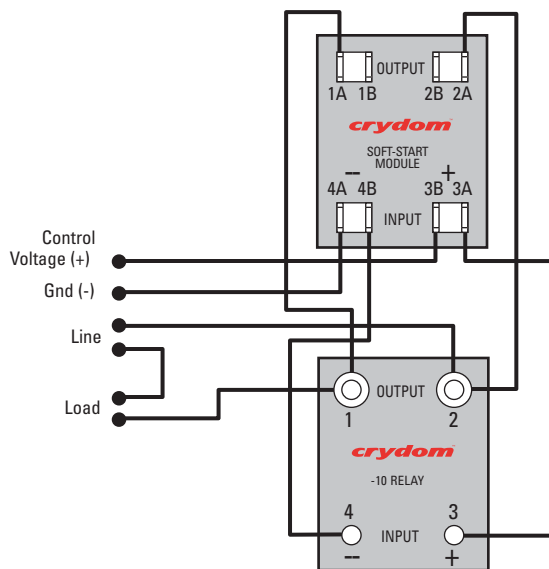

Notes

1. Following pins may be interchanged: 1A & 1B, 2A & 2B, 3A & 3B.
2. Pin 4A & 4B may not be interchanged.
3. The line and load may be interchanged.

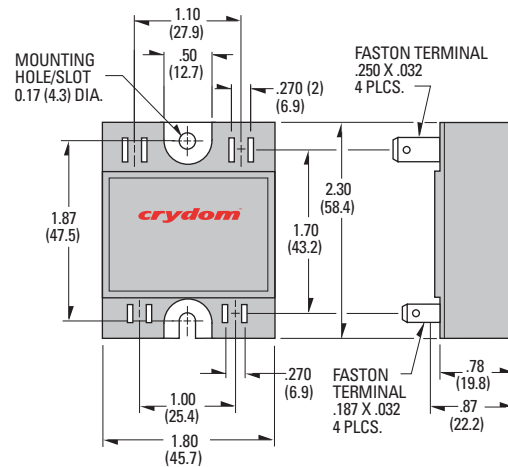

All dimensions are in inches (millimeters)

© 2007 CRYDOM Inc., Specifications subject to change without notice.

APPROVALS

UL E116949

For recommended applications and more information contact:

USA: Sales Support (877) 502-5500 **Tech Support** (877) 702-7700 FAX (619) 710-8540
Crydom Inc., 2320 Paseo de las Americas, Ste. 201, San Diego, CA 92154

Email: sales@crydom.com **WEB SITE:** http://www.crydom.com

UK: +44 (0)1202 606030 • **FAX** +44 (0)1202 606035 Crydom SSR Ltd., Arena Business Centre, Holyrood Close, Poole, Dorset BH17 7FJ, Email: intsales@crydom.com.

GERMANY: +49 (0)180 3000 506



! DANGER / PELIGRO / DANGER /GEFAHR / PERICOLO / PERIGO

| | | | | | |
|--------------------------------------------------------------------------------------------------------------------------------------------------------------------------------------------------------------------------------------------------------------------------------------------------------------------------------------------------------------------------|----------------------------------------------------------------------------------------------------------------------------------------------------------------------------------------------------------------------------------------------------------------------------------------------------------------------------------------------------------------------------------------------------------------|---------------------------------------------------------------------------------------------------------------------------------------------------------------------------------------------------------------------------------------------------------------------------------------------------------------------------------------------------------------------------------------------------------|----------------------------------------------------------------------------------------------------------------------------------------------------------------------------------------------------------------------------------------------------------------------------------------------------------------------------------------------------------------------------------------------------------------------------------------|---------------------------------------------------------------------------------------------------------------------------------------------------------------------------------------------------------------------------------------------------------------------------------------------------------------------------------------------------------------------------------------------------------------------------------------------------|---------------------------------------------------------------------------------------------------------------------------------------------------------------------------------------------------------------------------------------------------------------------------------------------------------------------------------------------------------------------------------------------------|
| <p>HAZARD OF ELECTRIC SHOCK, EXPLOSION, OR ARC FLASH.</p> <ul style="list-style-type: none"> • Disconnect all power before installing or working with this equipment. • Verify all connections and replace all covers before turning on power. <p>Failure to follow these instructions will result in death or serious injury.</p> | <p>RIESGO DE DESCARGA ELECTRICA O EXPLOSION.</p> <ul style="list-style-type: none"> • Desconectar todos los suministros de energia a este equipo antes de trabajar con este equipo. • Verificar todas las conexiones y colocar todas las tapas antes de energizar el equipo. <p>El incumplimiento de estas instrucciones puede provocar la muerte o lesiones serias.</p> | <p>RISQUE DE DESCARGE ELECTRIQUE OU EXPLOSION</p> <ul style="list-style-type: none"> • Eteindre toutes les sources d'énergie de cet appareil avant de travailler dessus de cet appareil • Vérifier tous connections, et remettre tous couverts en place avant de mettre sous <p>De non-suivi de ces instructions provoquera la mort ou des lésions sérieuses.</p> | <p>GEFAHR EINES ELEKTRISCHE N SCHLAGES ODER EINER EXPLOSION.</p> <ul style="list-style-type: none"> • Stellen Sie jeglichen Strom ab, der dieses Gerät versorgt, bevor Sie an dem Gerät Arbeiten durchführen • Vor dem Drehen auf Energie alle Anschlüsse überprüfen und alle Abdeckungen ersetzen. <p>Unterlassung dieser Anweisungen können zum Tode oder zu schweren Verletzungen führen.</p> | <p>RISCHIO DI SCOSSA ELETTRICA O DELL'ESPLOSIONE.</p> <ul style="list-style-type: none"> • Spenga tutta l'alimentazione e che fornisce questa apparecchiatura prima del lavorare a questa apparecchiatura • Verificare tutti i collegamenti e sostituire tutte le coperture prima della rotazione sull'alimentazione <p>L'omissione di seguire queste istruzioni provocherà la morte o di lesioni serie</p> | <p>RISCO DE DESCARGA ELÉTRICA OU EXPLOSÃO</p> <ul style="list-style-type: none"> • Desconectar o equipamento de toda a energia antes de instalar ou trabalhar com este equipamento • Verificar todas as conexões e recolocar todas as tampas antes de religar o equipamento <p>O não cumprimento destas instruções pode levar à morte ou lesões sérias.</p> |
|--------------------------------------------------------------------------------------------------------------------------------------------------------------------------------------------------------------------------------------------------------------------------------------------------------------------------------------------------------------------------|----------------------------------------------------------------------------------------------------------------------------------------------------------------------------------------------------------------------------------------------------------------------------------------------------------------------------------------------------------------------------------------------------------------|---------------------------------------------------------------------------------------------------------------------------------------------------------------------------------------------------------------------------------------------------------------------------------------------------------------------------------------------------------------------------------------------------------|----------------------------------------------------------------------------------------------------------------------------------------------------------------------------------------------------------------------------------------------------------------------------------------------------------------------------------------------------------------------------------------------------------------------------------------|---------------------------------------------------------------------------------------------------------------------------------------------------------------------------------------------------------------------------------------------------------------------------------------------------------------------------------------------------------------------------------------------------------------------------------------------------|---------------------------------------------------------------------------------------------------------------------------------------------------------------------------------------------------------------------------------------------------------------------------------------------------------------------------------------------------------------------------------------------------|

! WARNING / AVERTISSEMENT / WARNUNG /ADVERTENCIA / AVVERTENZA / AVISO

| | | |
|-------------------------------------------------------------------------------------------------------------------------------------------------------------------------------------------------------------------------------------------------------------------------------------------------------------------------------------------------------------------------------------------------------------------------------------------------------------------------------------------------------------------------------|----------------------------------------------------------------------------------------------------------------------------------------------------------------------------------------------------------------------------------------------------------------------------------------------------------------------------------------------------------------------------------------------------------------------------------------------------------------------------------------------------------------------------------------------|-----------------------------------------------------------------------------------------------------------------------------------------------------------------------------------------------------------------------------------------------------------------------------------------------------------------------------------------------------------------------------------------------------------------------------------------------------------------------------|
| <p>RISK OF MATERIAL DAMAGE AND HOT ENCLOSURE</p> <ul style="list-style-type: none"> • The product's side panels may be hot, allow time for product to cool before touching. • Follow proper mounting instructions including torque values. • Do not allow liquids or foreign objects to enter this product. <p>Failure to follow this instruction can result in serious injury, or equipment damage.</p> | <p>RISQUE DE DOMMAGE MATERIEL ET DE SURCHAUFFE DU BOITIER</p> <ul style="list-style-type: none"> • Les panneaux latéraux du produit peuvent être chauds. Laisser le produit refroidir avant de le toucher. • Respecter les consignes de montage, et notamment les couples de serrage. • Ne pas laisser pénétrer de liquide ni de corps étrangers à l'intérieur du produit. <p>Le non-respect de cette directive peut entraîner, des lésions corporelles graves ou des dommages matériels.</p> | <p>GEFAHR VON MATERIALSCHÄDEN UND GEHÄUSEERHITZUNG</p> <ul style="list-style-type: none"> • Die Seitenwände können heiß sein. Lassen Sie das Produkt abkühlen, bevor Sie es berühren. • Beachten Sie die Montageanweisungen, • Führen Sie keine Flüssigkeiten oder Fremdkörper in das Produkt ein. <p>Die Nichtbeachtung dieser Anweisung kann Körperverletzung oder Materialschäden zur Folge haben.</p> |
| <p>RIESGO DE DAÑOS MATERIALES Y DE SOBRECIENTAMIENTO DE LA UNIDAD</p> <ul style="list-style-type: none"> • Los paneles laterales del producto pueden estar calientes. Esperar que el producto se enfríe antes de tocarlo. • Respetar las instrucciones de montaje, y en particular los pares de apretado. • No dejar que penetren líquidos o cuerpos extraños en el producto. <p>Si no se respetan estas precauciones pueden producirse graves lesiones, daños materiales.</p> | <p>RISCHIO DI DANNI MATERIALI E D'INVOLUCRO CALDO</p> <ul style="list-style-type: none"> • I pannelli laterali dell'apparecchio possono scottare; lasciar quindi raffreddare il prodotto prima di toccarlo. • Seguire le istruzioni di montaggio corrette. • Non far entrare liquidi o oggetti estranei in questo apparecchio. <p>La mancata osservanza di questa precauzione può causare gravi rischi per l'incolumità personale o danni alle apparecchiature.</p> | <p>RISCO DE DANO MATERIAL E DE AQUECIMENTO</p> <ul style="list-style-type: none"> • Os painéis laterais do produto podem estar quentes; dê tempo ao produto para arrefecer antes de lhe tocar. • Siga devidamente as instruções de montagem. • Não permita a entrada de líquidos e de objectos estranhos no produto. <p>A não observância destas precauções pode provocar a morte, ferimentos graves ou danos materiais.</p> |

ANNEX – ENVIRONMENTAL INFORMATION:

The environmental information disclosed in this annex including the EIP Pollution logo are in compliance with People's Republic of China Electronic Industry Standard SJ/T11364 – 2006, Marking for Control of Pollution Caused by Electronic Information Products.

| Part Name | Toxic or hazardous Substance and Elements | | | | | |
|-------------------|-------------------------------------------|--------------|--------------|-------------------------------|--------------------------------|---------------------------------------|
| | Lead (Pb) | Mercury (Hg) | Cadmium (Cd) | Hexavalent Chromium (Cr (VI)) | Polybrominated biphenyls (PBB) | Polybrominated diphenyl ethers (PBDE) |
| Semiconductor die | X | O | O | O | O | O |
| Solder | X | O | O | O | O | O |

附件 - 环保信息:

此附件所标示的包括电子信息产品污染图标的环保信息符合中华人民共和国电子行业标准 **SJ/T11364 - 2006**, 电子信息产品污染控制标识要求

| 部件名称 | 有毒有害物质或元素 | | | | | |
|-------|-----------|--------|--------|---------------|------------|--------------|
| | 铅 (Pb) | 汞 (Hg) | 镉 (Cd) | 六价铬 (Cr (VI)) | 多溴联苯 (PBB) | 多溴二苯醚 (PBDE) |
| 半导体芯片 | X | O | O | O | O | O |
| 焊接点 | X | O | O | O | O | O |

